

Rotary Breakers

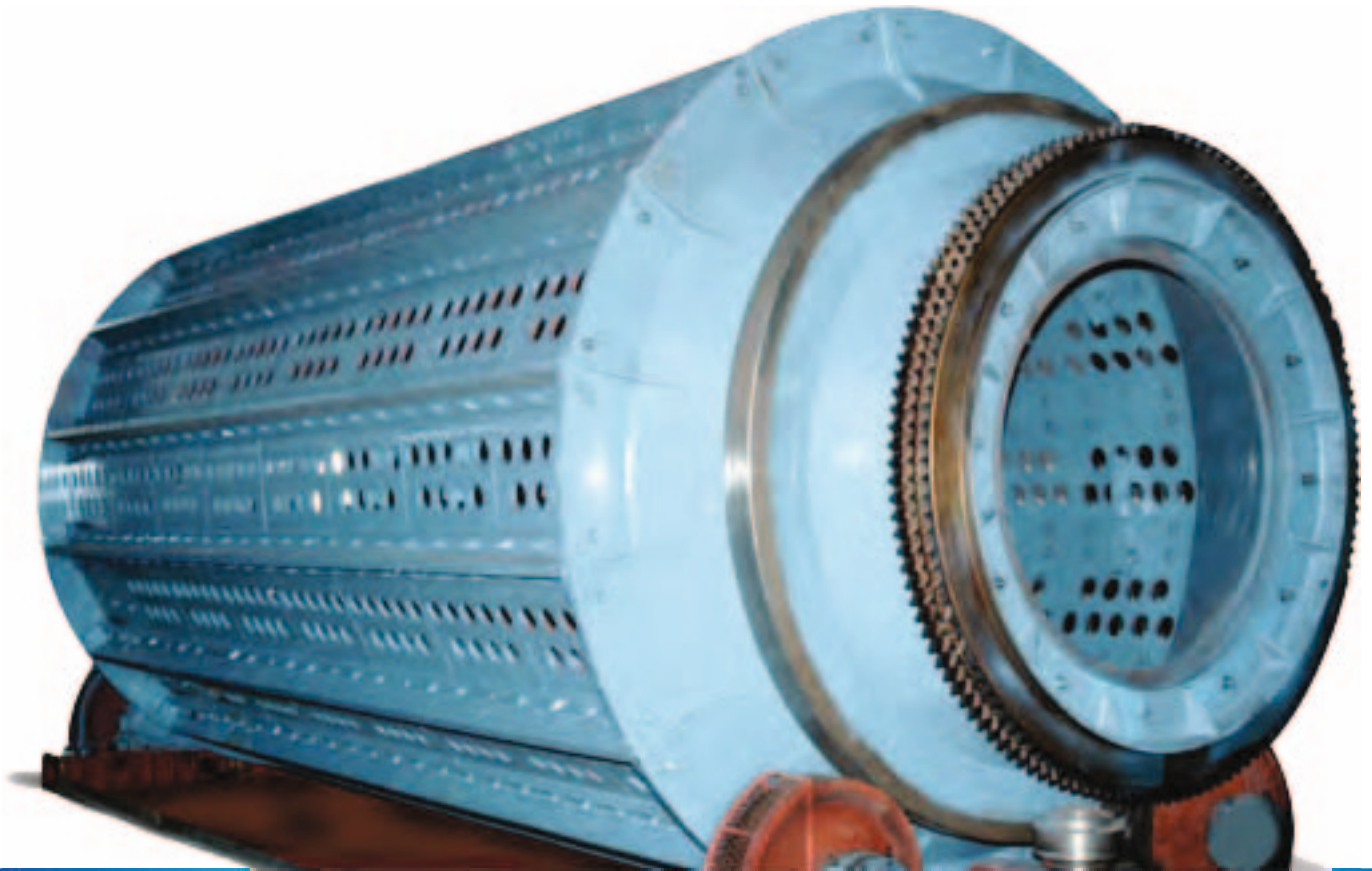

TECHNICAL SPECIFICATIONS

- Extremely durable and designed for high tonnage output
- Bolted design for easy replacement
- Totally enclosed dust housing for pollution free environment
- Totally enclosed dust housing for pollution free environment
- Low RPM ensures less vibration and low noise

Rotary Breakers

Introduction

The TRF made Rotary Breaker is essentially a large rotating cylinder, powered by an electric motor through a chain reducer drive. TRF Breakers crush by gravity impact only. The cylinder is fitted with perforated screen plates, lifting shelves, deflectors and a refuse plow. The size of the screen plate perforations determines the maximum product size of the coal to be processed.

Coal is introduced through one end of the cylinder known as the 'feed end'. Product size coal in the feed is first screened through the perforated screen plates. Larger coal is directed further into the cylinder by the deflectors to the lifting shelves, where it is lifted and dropped onto the screen plates, shattering on impact. Impacting in this fashion causes fractures along natural cleavage lines resulting in minimum production of fines in the product passing through the screen plate openings. Coal that is not product size continues to be lifted and dropped until it passes through the screen plate.

Rock, slate, and other materials that resist breakage and enter the breaker with the feed eventually flow to the discharge end

of the cylinder where they are ejected by the refuse plough. It must operate at the cylinder R.P.M. listed on the specification sheet in the manual. Increasing the speed will not increase the capacity of the breaker. Operating the breaker with increased R.P.M. more than specified will not result in efficiency.

The breaker is enclosed in a fabricated steel casing. Both feed and refuse chutes are necessary to feed coal to the cylinder and dispose of the rejects.

TRF's Rotary Breaker achieves reduction by repeatedly raising the feed material and dropping it against strong, perforated screen plates around the interior. Adjustable lifter shelves raise the feed material and control the rate of material movement. This lifting and dropping action effectively crushes soft to medium hard material, which then passes through the screen openings to a collection hopper below. Hard rock and uncrushable materials are discharged out the end of the cylinder with the aid of a discharge plow.

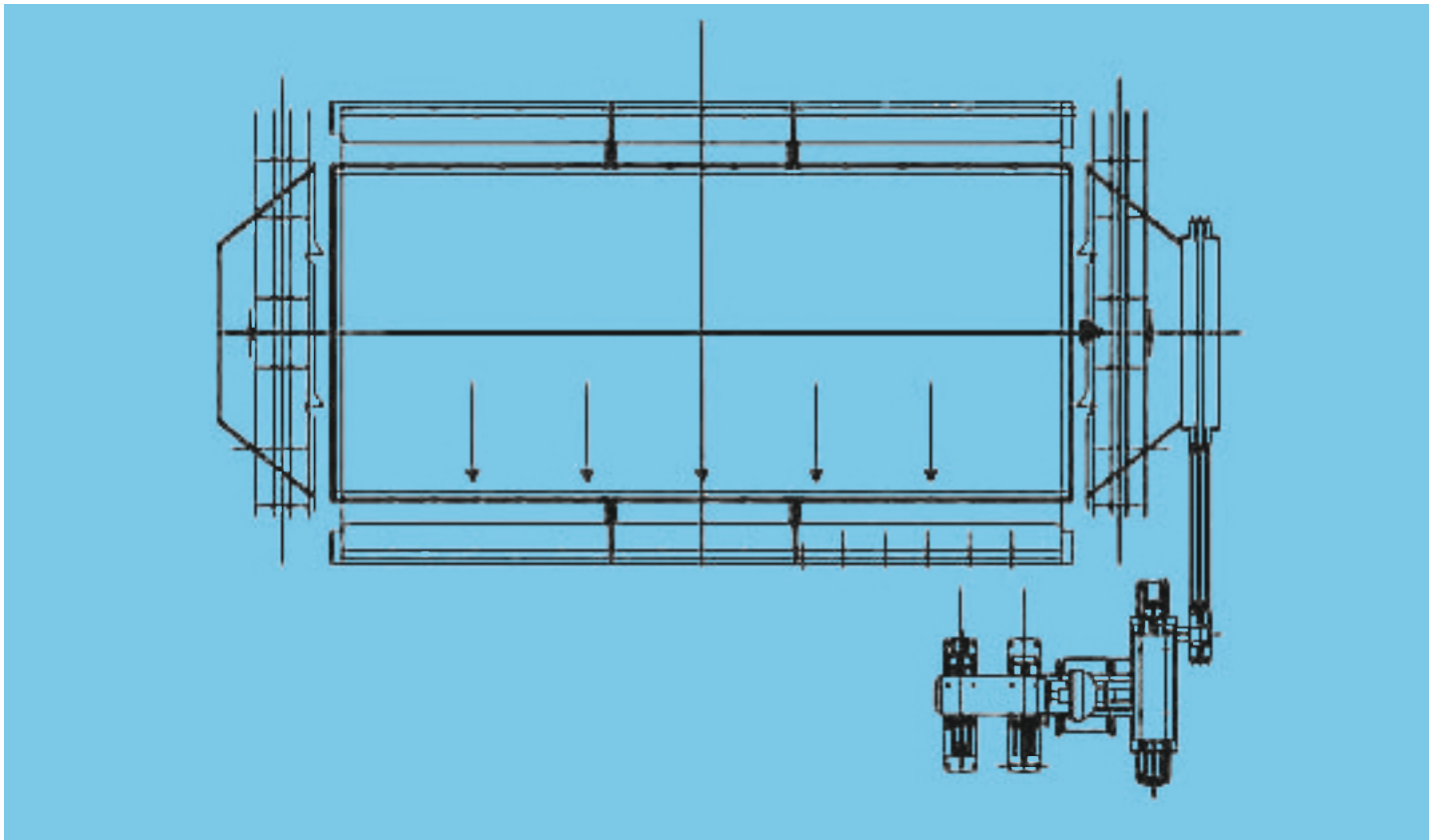

Plan view for foundation of Rotary Breaker

The capacity chart below provides a starting point of the standard sizes available from TRF. Customizing a machine designed for the customer's use (length and diameter) to maximize their return on investment is TRF's goal.

Capacity

Breaker (Diameter xLength)	1½ 38mm	2" 50mm	2½ 63mm	3" 76mm	3½ 89mm	4" 102mm	5" 127mm	6" 152mm	8" 203mm
9' x 17'	278★ 252	376 341	471 427	486 441	500 454	514 466	572 519	640 581	858 778
10.5' x 19'	415 376	561 509	702 637	724 657	745 676	766 694	852 773	955 866	1278 1159
12' x 22'	580 526	783 710	981 890	1011 971	1041 944	1071 971	1190 1080	1335 1211	1785 1619
12' x 28'	745 676	1007 913	1262 1145	1300 1180	1338 1214	1377 1249	1530 1388	1720 1560	2295 2082
12' x 24'	650 590	881 799	1103 1001	1137 1092	1171 1062	1205 1092	1339 1215	1502 1362	2008 1821

★ Top numbers are short tonnes per hour, bottom are metric tonnes per hour

Cylinder Construction

SCREEN FRAME is fabricated of wide-flange steel beams precisely drilled for attachment of screen plates. The beam ends are then either bolted to the end directions with body-bound bolts or welded fast, depending upon transportation and/or assembly restrictions.

SCREEN PLATES fabricated with the correct sized holes to provide the desired product size.

Note: holes sizes are usually slightly larger than the nominal product requirement.

LIFTERS are composed of abrasion resistant longitudinal steel lifter angles, bolted to the screen frame beams. These are adjustable either to retard or advance the flow of material through the breaker. Separate bolts hold the lifters, so that the screen plates are not loosened when adjusting the angle of pitch.

Machining

The end sections are machined in a bolt together with the beams, which are made to jigs and machined on both ends, are then fitted and aligned to ensure that the unit runs concentric. When the beams are bolted to the end sections. In operation, your Rotary Breaker runs quieter and smoother with reduced bearing maintenance, which ultimately means longer life and lower cost per ton produced.



Assembly of Rotary Breaker

Drive

An engineering class chain that wraps around the cylinder is a standard item on TRF's Rotary Breakers. A segmented, driven sprocket is bolted to a machined base at the feed end and a drive sprocket is mounted on the reducer output shaft. A sealed protective chain case is equipped with splash lubrication. A steel-cased reducer is foot mounted on a common base plate with the motor and power is transmitted from the motor to the reducer via a torque limiting coupling. Inching drives are available to provide a safer means of slowly rotating the cylinder for maintenance purposes.

Tires & Trunnion Rollers

Four independently adjustable trunnion rollers support the breaker cylinder. The main cylinder tires are wide faced and are constructed of one piece high carbon forged steel that is shrunk fit to the machine's tire base.

Trunnion rollers also incorporate renewable, high carbon forged steel tires. Each trunnion roller is supported by two heavy duty, shaft-mounted pillow block roller bearings that are adapter mounted and grease lubricated with grease lines grouped at a common point to facilitate maintenance. Thrust rollers at the feed and discharge ends of the breaker cylinder prevent lateral movement.

Base Frame

A full length base frame is an available option as it provides easy set up and alignment in the field to ensure a level operating condition.

Drop Tests

Drop test will allow you to determine the diameter and length of a breaker needed to process your application.

Dust Housings & Chutes

The main dust housing is sectionalized with inspection doors located on both its sides to facilitate maintenance.

Sloped section under the breaker converges discharged material to the conveyor. Optional chutes at the feed and discharge ends can be furnished with AR steel liners in the chutes as standard.

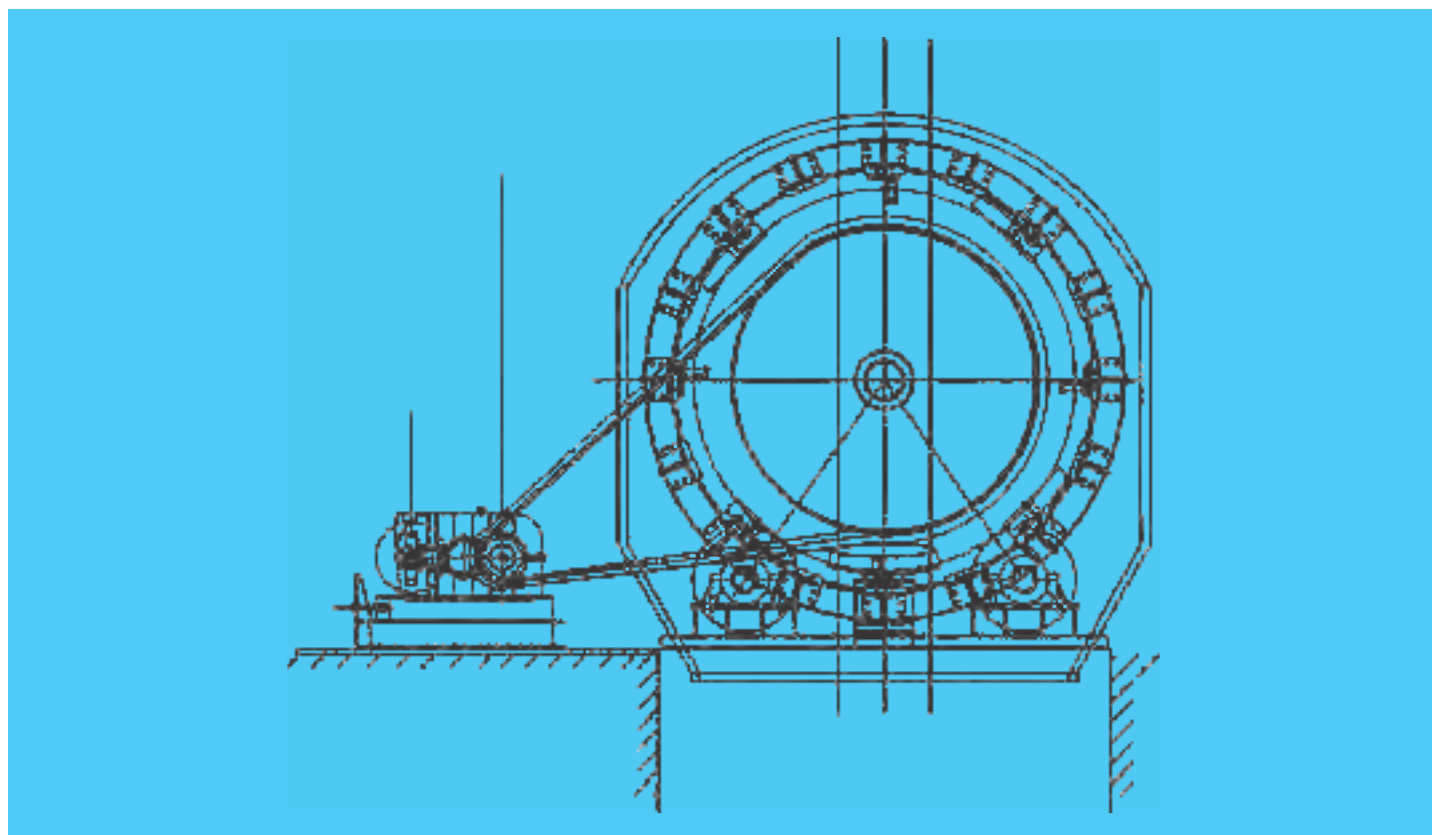

Side view of Rotary Breaker

HEAD OFFICE & WORKS

TRF Limited

11, Station Road Burma Mines, Jamshedpur-831007, Jharkhand
Phone : +91-657-2345721, e-mail : lcs@trf.co.in
Website : www.trf.co.in